

# FM520-ASF THRU FM5200-ASF

## List

List.....	1
Package outline.....	2
Features.....	2
Mechanical data.....	2
Maximum ratings and Electrical characteristics .....	2
Rating and characteristic curves.....	3
Pinning information.....	4
Marking.....	4
Suggested solder pad layout.....	4
Packing information.....	5
Reel packing.....	6
Suggested thermal profiles for soldering processes.....	6
High reliability test capabilities.....	7

# FM520-ASF THRU FM5200-ASF

## 5.0A Surface Mount Schottky Barrier Rectifiers 20V-200V

### Features

- Batch process design, excellent power dissipation offers better reverse leakage current and thermal resistance
- Low profile surface mounted application in order to optimize board space
- Low power loss, high efficiency
- High current capability, low forward voltage drop
- High surge capability
- Guardring for overvoltage protection
- Ultra high-speed switching
- Silicon epitaxial planar chip, metal silicon junction
- Lead-free parts meet RoHS requirements
- Suffix "-H" indicates Halogen-free part, ex.FM520-ASF-H

### Mechanical data

- Epoxy:UL94-V0 rated flame retardant
- Case : Molded plastic, SMA-SF
- Terminals : Solder plated, solderable per MIL-STD-750, Method 2026
- Polarity : Indicated by cathode band
- Mounting Position : Any
- Weight : Approximated 0.04 gram

### Package outline

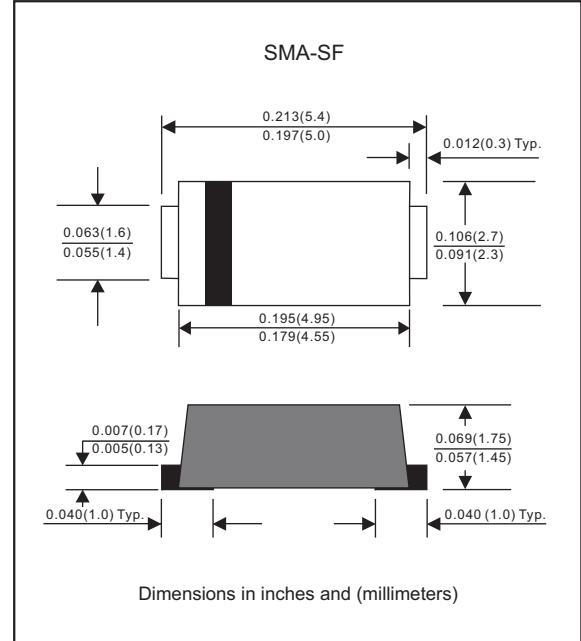

### Maximum ratings (AT T<sub>A</sub>=25°C unless otherwise noted)

PARAMETER	SYMBOLS	FM520-ASF	FM530-ASF	FM540-ASF	FM550-ASF	FM560-ASF	FM580-ASF	FM5100-ASF	FM5150-ASF	FM5200-ASF	UNIT	
Maximum repetitive peak reverse voltage	V <sub>RRM</sub>	20	30	40	50	60	80	100	150	200	V	
Maximum RMS voltage	V <sub>RMS</sub>	14	21	28	35	42	56	70	105	140	V	
Maximum continuous reverse voltage	V <sub>R</sub>	20	30	40	50	60	80	100	150	200	V	
Maximum average forward rectified current	I <sub>O</sub>	5.0									A	
Non-repetitive peak forward surge current 8.3ms single half sine-wave	I <sub>FSM</sub>	100									A	
Typical junction capacitance (Note 1)	C <sub>J</sub>	380									pF	
Operating junction temperature range	T <sub>J</sub>	-55 to +125				-55 to +150						°C
Storage temperature range	T <sub>STG</sub>	-65 to +175									°C	

### Electrical characteristics (AT T<sub>A</sub>=25°C unless otherwise noted)

PARAMETER	SYMBOLS	FM520-ASF	FM530-ASF	FM540-ASF	FM550-ASF	FM560-ASF	FM580-ASF	FM5100-ASF	FM5150-ASF	FM5200-ASF	UNIT
Maximum instantaneous forward voltage at I <sub>F</sub> =5.0A	V <sub>F</sub>	0.55			0.70		0.85	0.90	0.92	V	
Maximum reverse leakage current at rated V <sub>R</sub>	I <sub>R</sub>	0.1 20				0.05 10		0.01 5			mA mA

### Thermal characteristics

PARAMETER	SYMBOLS	FM520-ASF	FM530-ASF	FM540-ASF	FM550-ASF	FM560-ASF	FM580-ASF	FM5100-ASF	FM5150-ASF	FM5200-ASF	UNIT	
Typical thermal resistance junction to ambient (Note2)	R <sub>θJA</sub>	56					28					°C/W
Typical thermal resistance junction to case (Note 2)	R <sub>θJC</sub>	28										°C/W

Notes1: Measured at 1MHz and applied reverse voltage of 4.0V D.C  
 2: Mounted on FR-4 PCB copper, minimum recommended pad layout

# Rating and characteristic curves (FM520-ASF THRU FM5200-ASF)

FIG.1-TYPICAL FORWARD CURRENT DERATING CURVE

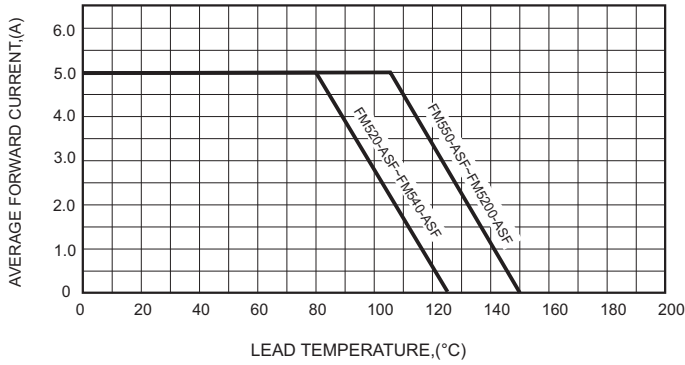

FIG.2-TYPICAL FORWARD CHARACTERISTICS

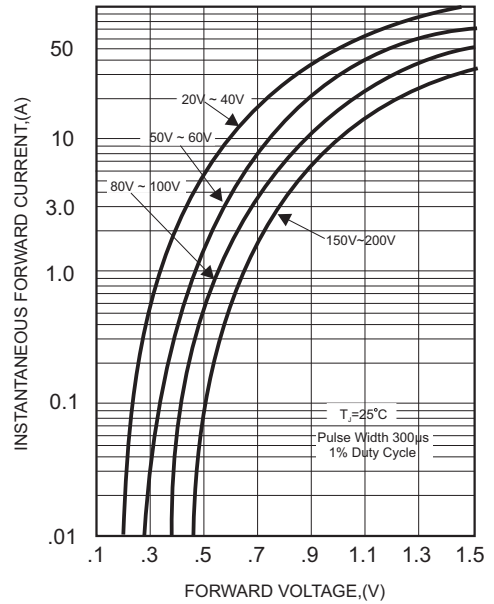

FIG.3-MAXIMUM NON-REPETITIVE FORWARD SURGE CURRENT

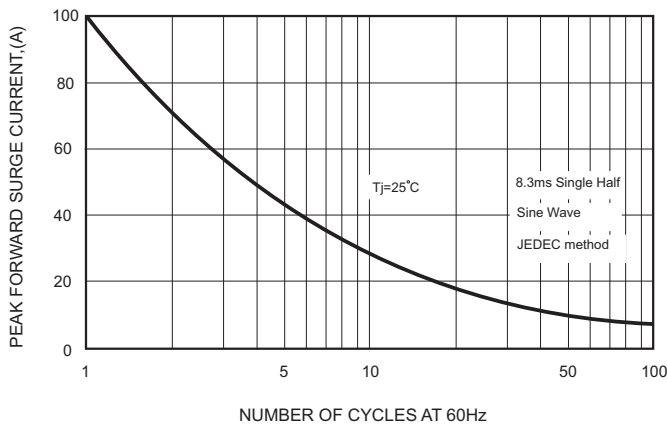

FIG.5 - TYPICAL REVERSE CHARACTERISTICS

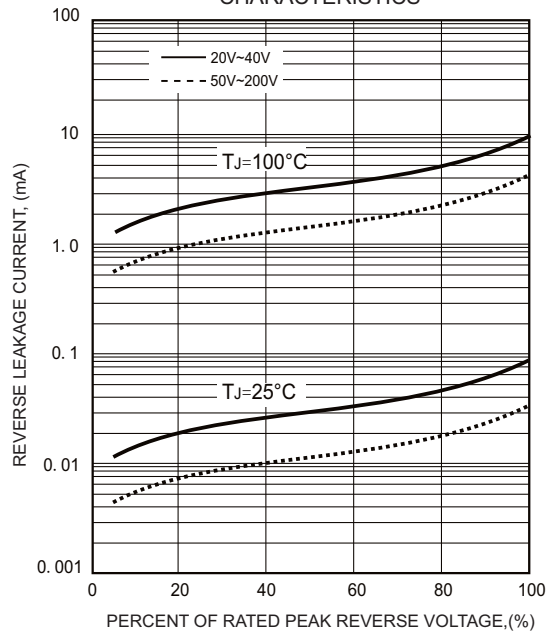
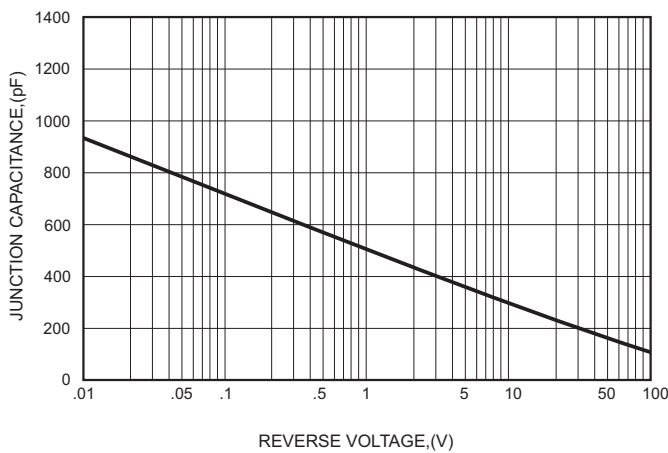



FIG.4-TYPICAL JUNCTION CAPACITANCE



# FM520-ASF THRU FM5200-ASF

## Pinning information

Pin	Simplified outline	Symbol
Pin1 cathode Pin2 anode		

## Marking

Type number	Marking code
FM520-ASF	SS52
FM530-ASF	SS53
FM540-ASF	SS54
FM550-ASF	SS55
FM560-ASF	SS56
FM580-ASF	SS58
FM5100-ASF	S510
FM5150-ASF	S515
FM5200-ASF	S520

## Suggested solder pad layout

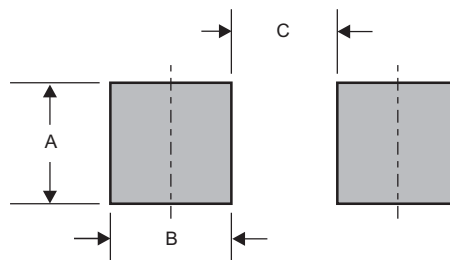

Dimensions in inches and (millimeters)

PACKAGE	A	B	C
SMA-SF	0.063 (1.60)	0.059 (1.50)	0.110 (2.80)

# FM520-ASF THRU FM5200-ASF

## Packing information

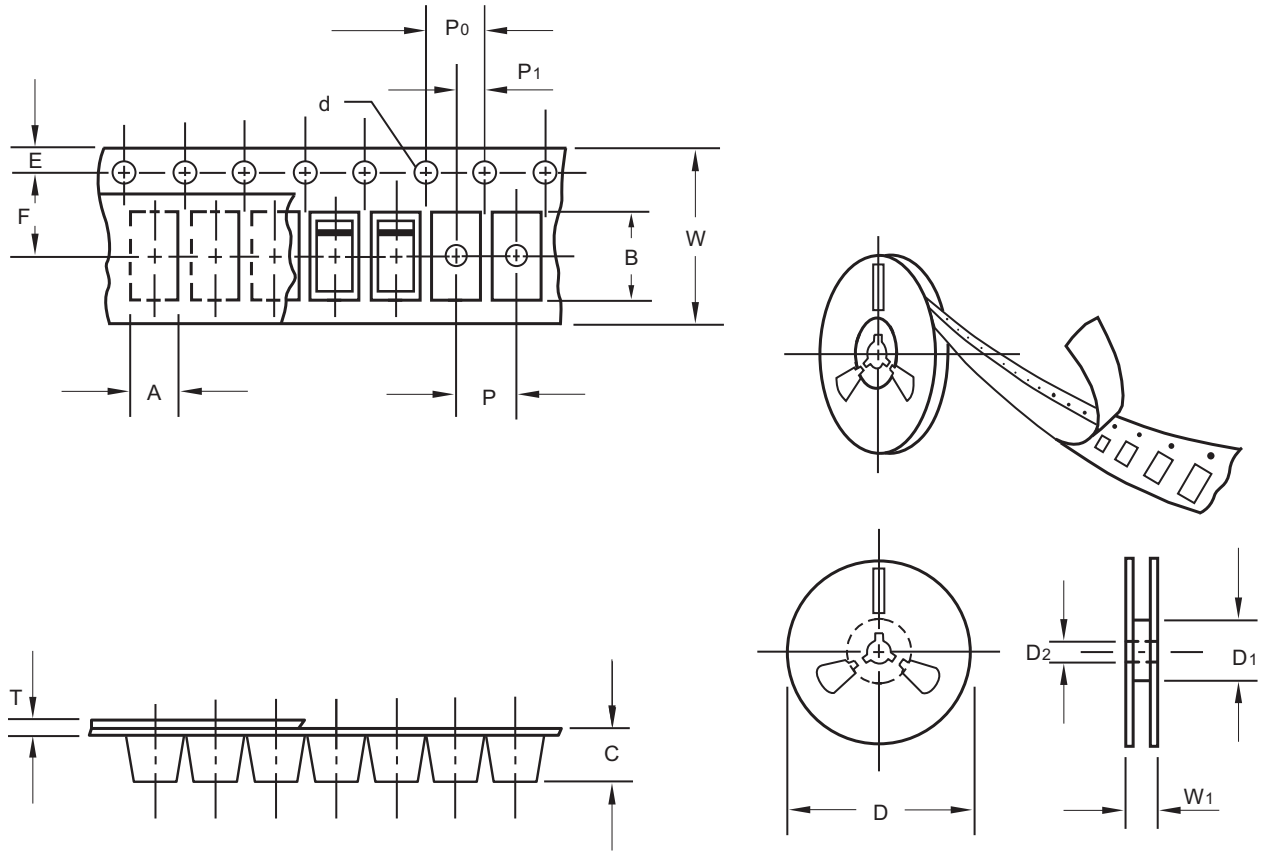

unit:mm

Item	Symbol	Tolerance	SMA-SF
Carrier width	A	0.1	2.90
Carrier length	B	0.1	5.50
Carrier depth	C	0.1	2.10
Sprocket hole	d	0.1	1.50
13" Reel outside diameter	D	2.0	330.00
13" Reel inner diameter	D1	min	50.00
7" Reel outside diameter	D	2.0	178.00
7" Reel inner diameter	D1	min	62.00
Feed hole diameter	D2	0.5	13.00
Sprocket hole position	E	0.1	1.75
Punch hole position	F	0.1	5.50
Punch hole pitch	P	0.1	4.00
Sprocket hole pitch	P0	0.1	4.00
Embossment center	P1	0.1	2.00
Overall tape thickness	T	0.1	0.23
Tape width	W	0.3	12.00
Reel width	W1	1.0	18.00

Note: Devices are packed in accordance with EIA standard RS-481-A and specifications listed above.

# FM520-ASF THRU FM5200-ASF

## Reel packing

PACKAGE	REEL SIZE	REEL (pcs)	COMPONENT SPACING (m/m)	BOX (pcs)	INNER BOX (m/m)	REEL DIA, (m/m)	CARTON SIZE (m/m)	CARTON (pcs)	APPROX. GROSS WEIGHT (kg)
SMA-SF	7"	2,000	4.0	20,000	183*155*183	178	382*356*392	160,000	12.0
	13"	7,500	4.0	15,000	335*335*38	330	350*330*360	120,000	11.5

## Suggested thermal profiles for soldering processes

- 1.Storage environment: Temperature=5°C~40°C Humidity=55%±25%
- 2.Reflow soldering of surface-mount devices

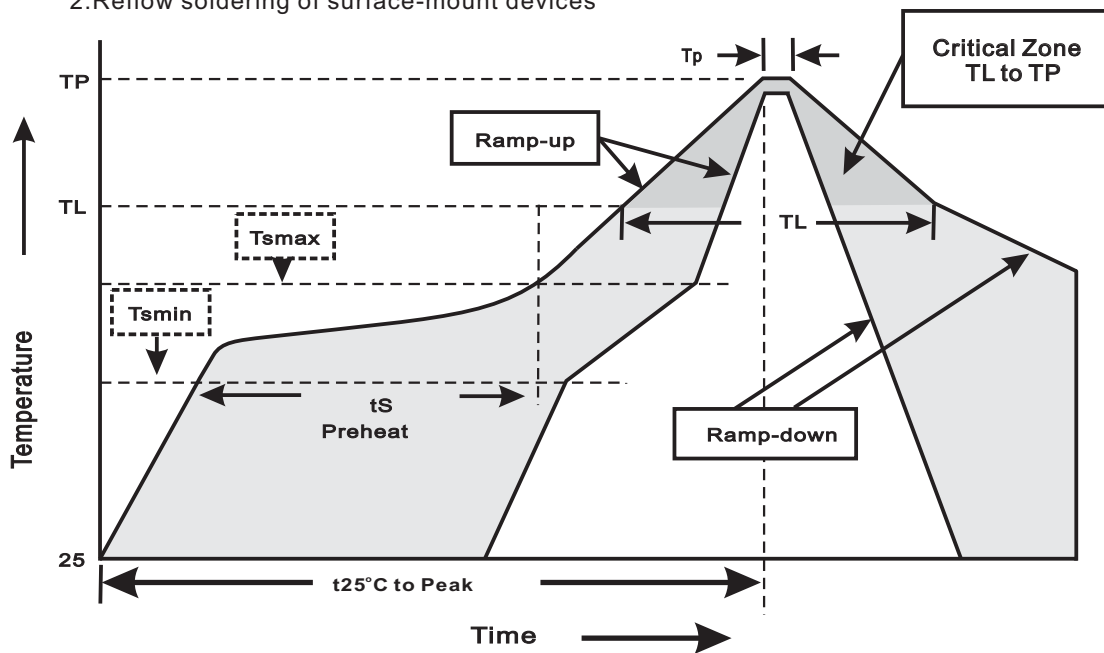

### 3.Reflow soldering

Profile Feature	Soldering Condition
Average ramp-up rate(T <sub>L</sub> to T <sub>P</sub> )	<3°C/sec
Preheat -Temperature Min(T <sub>smin</sub> ) -Temperature Max(T <sub>smax</sub> ) -Time(min to max)(t <sub>s</sub> )	150°C 200°C 60~120sec
T <sub>smax</sub> to T <sub>L</sub> -Ramp-upRate	<3°C/sec
Time maintained above: -Temperature(T <sub>L</sub> ) -Time(t <sub>L</sub> )	217°C 60~260sec
Peak Temperature(T <sub>P</sub> )	255°C-0/+5°C
Time within 5°C of actual Peak Temperature(t <sub>P</sub> )	10~30sec
Ramp-down Rate	<6°C/sec
Time 25°C to Peak Temperature	<6minutes

**FM520-ASF THRU FM5200-ASF****High reliability test capabilities**

Item Test	Conditions	Reference
1. Solder Resistance	at 260±5°C for 10±2sec.	MIL-STD-750D METHOD-2031
2. Solderability	at 245±5°C for 5 sec.	MIL-STD-202F METHOD-208
3. High Temperature Reverse Bias	$V_R=80\%$ rate at $T_J=125^\circ\text{C}$ for 168 hrs.	MIL-STD-750D METHOD-1038
4. Forward Operation Life	Rated average rectifier current at $T_A=25^\circ\text{C}$ for 500hrs.	MIL-STD-750D METHOD-1027
5. Intermittent Operation Life	$T_A = 25^\circ\text{C}$ , $I_F = I_O$ On state: power on for 5 min. off state: power off for 5 min. on and off for 500 cycles.	MIL-STD-750D METHOD-1036
6. Pressure Cooker	15P <sub>SIG</sub> at $T_A=121^\circ\text{C}$ for 4 hrs.	JESD22-A102
7. Temperature Cycling	-55°C to +125°C dwelled for 30 min. and transferred for 5min. total 10 cycles.	MIL-STD-750D METHOD-1051
8. Forward Surge	8.3ms single half sine-wave , one surge.	MIL-STD-750D METHOD-4066-2
9. Humidity	at $T_A=85^\circ\text{C}$ , RH=85% for 1000hrs.	MIL-STD-750D METHOD-1021
10. High Temperature Storage Life	at 175°C for 1000 hrs.	MIL-STD-750D METHOD-1031