

# FM2L40-N

## List

List..... 1

Package outline..... 2

Features..... 2

Mechanical data..... 2

Maximum ratings and Electrical characteristics ..... 2

Rating and characteristic curves..... 3

Pinning information..... 4

Marking..... 4

Suggested solder pad layout..... 4

Packing information..... 5

Reel packing..... 6

Suggested thermal profiles for soldering processes..... 6

High reliability test capabilities..... 7

# FM2L40-N

## 2.0A Low VF Surface Mount Schottky Barrier Rectifiers 40V

### Features

- High current density schottky
- Low power loss, high efficiency
- High current capability, low forward voltage drop
- High surge capability
- Very tiny plastic SMD package
- Lead-free parts meet RoHS requirements
- Suffix "-H" indicates Halogen-free part, ex.FM2L40-N-H

### Mechanical data

- Epoxy : UL94-V0 rated flame retardant
- Case : Molded plastic, SOD-323
- Terminals :Plated terminals, solderable per MIL-STD-750, Method 2026
- Polarity : Indicated by cathode band
- Mounting Position : Any
- Weight : Approximated 0.008 gram

### Package outline

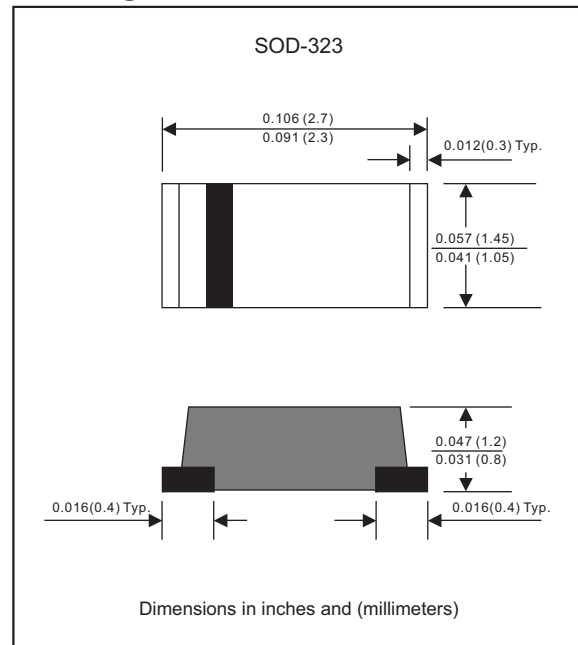

### Maximum ratings (AT T<sub>A</sub>=25°C unless otherwise noted)

PARAMETER	SYMBOLS	FM2L40-N	UNITS
Maximum repetitive peak reverse voltage	V <sub>RRM</sub>	40	Volts
Maximum RMS voltage	V <sub>RMS</sub>	28	Volts
Maximum continuous reverse voltage	V <sub>R</sub>	40	Volts
Maximum average forward rectified current	I <sub>O</sub>	2.0	A
Non-repetitive peak forward surge current 1.0ms square-wave	I <sub>FSM</sub>	40	A
Typical junction capacitance (Note 1)	C <sub>J</sub>	90	pF
Operating junction temperature range	T <sub>J</sub>	-55 to +125	°C
Storage temperature range	T <sub>STG</sub>	-65 to +175	°C

### Electrical characteristics (AT T<sub>A</sub>=25°C unless otherwise noted)

PARAMETER	SYMBOLS	FM2L40-N	UNITS
Maximum instantaneous forward voltage at I <sub>F</sub> =2.0A ,T <sub>J</sub> =25°C	V <sub>F</sub>	0.48	Volts
Maximum reverse leakage current at V <sub>R</sub> =40V ,T <sub>J</sub> =25°C V <sub>R</sub> =40V ,T <sub>J</sub> =100°C	I <sub>R</sub>	0.5 20	mA mA

### Thermal characteristics

PARAMETER	SYMBOLS	FM2L40-N	UNITS
Typical thermal resistance junction to ambient (Note 2)	R <sub>θJA</sub>	80	°C / W
Typical thermal resistance junction to case (Note 2)	R <sub>θJC</sub>	70	°C / W

Notes1: Measured at 1MHz and applied reverse voltage of 4.0V D.C  
2: Mounted on FR-4 PCB copper, minimum recommended pad layout

## Rating and characteristic curves (FM2L40-N)

FIG.1-TYPICAL FORWARD CHARACTERISTICS

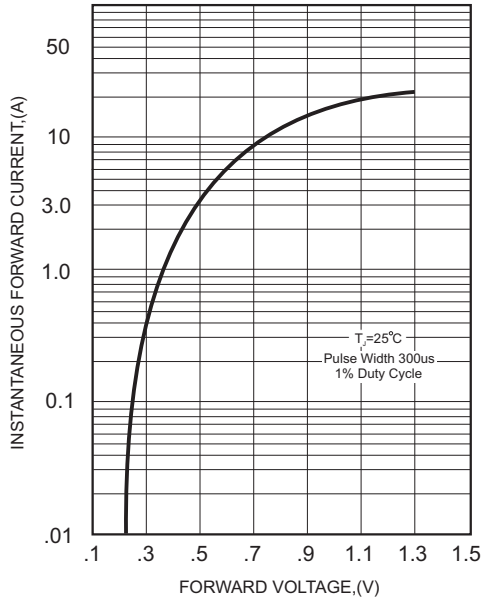

FIG.2-TYPICAL FORWARD CURRENT DERATING CURVE

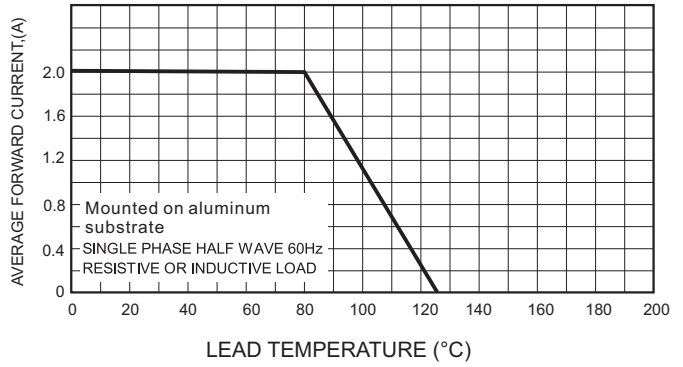

FIG.4-MAXIMUM NON-REPETITIVE FORWARD SURGE CURRENT

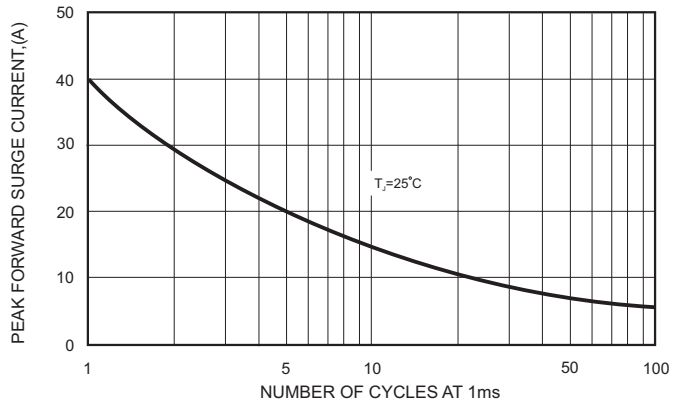

FIG.3 - TYPICAL REVERSE CHARACTERISTICS

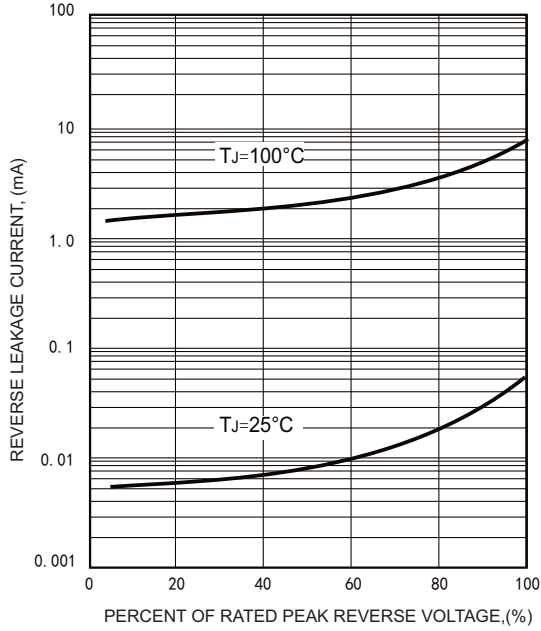
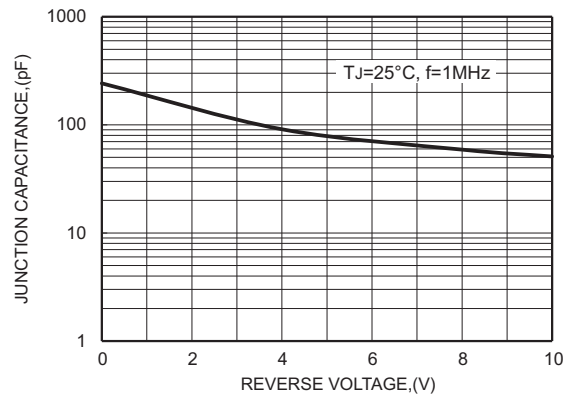



FIG.5-TYPICAL JUNCTION CAPACITANCE



# FM2L40-N

## Pinning information

Pin	Simplified outline	Symbol
Pin1 cathode Pin2 anode		

## Marking

Type number	Marking code
FM2L40-N	L4

## Suggested solder pad layout

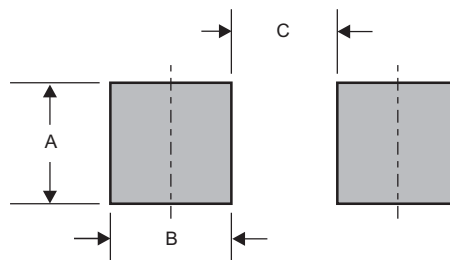

Dimensions in inches and (millimeters)

PACKAGE	A	B	C
SOD-323	0.059 (1.50)	0.039 (1.00)	0.051 (1.30)

# FM2L40-N

## Packing information

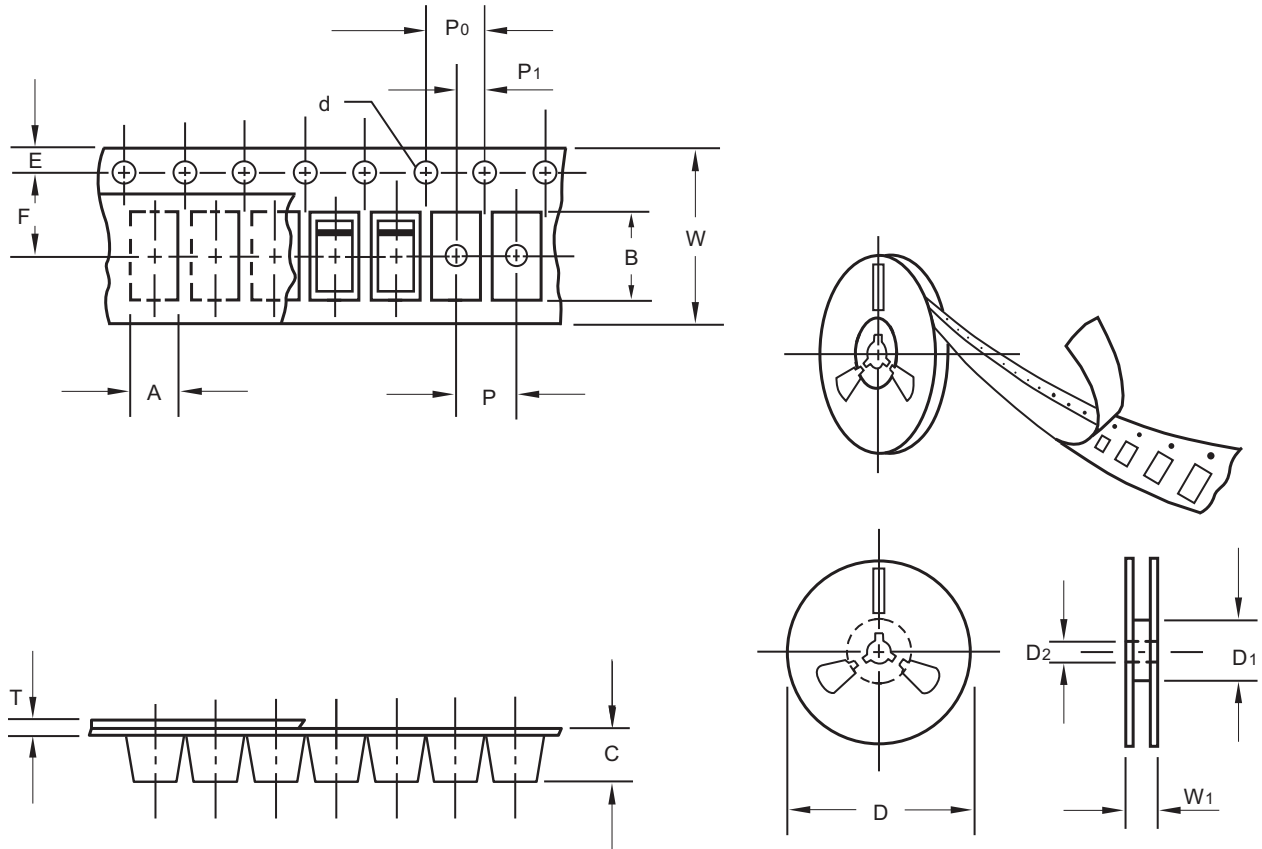

unit:mm

Item	Symbol	Tolerance	SOD-323
Carrier width	A	0.1	1.47
Carrier length	B	0.1	2.95
Carrier depth	C	0.1	1.15
Sprocket hole	d	0.1	1.50
13" Reel outside diameter	D	2.0	-
13" Reel inner diameter	D1	min	-
7" Reel outside diameter	D	2.0	178.00
7" Reel inner diameter	D1	min	62.00
Feed hole diameter	D2	0.5	13.00
Sprocket hole position	E	0.1	1.75
Punch hole position	F	0.1	3.50
Punch hole pitch	P	0.1	4.00
Sprocket hole pitch	P0	0.1	4.00
Embossment center	P1	0.1	2.00
Overall tape thickness	T	0.1	0.23
Tape width	W	0.3	8.00
Reel width	W1	1.0	11.40

Note: Devices are packed in accordance with EIA standard RS-481-A and specifications listed above.

# FM2L40-N

## Reel packing

PACKAGE	REEL SIZE	REEL (pcs)	COMPONENT SPACING (m/m)	BOX (pcs)	INNER BOX (m/m)	REEL DIA, (m/m)	CARTON SIZE (m/m)	CARTON (pcs)	APPROX. GROSS WEIGHT (kg)
SOD-323	7"	3,000	4.0	30,000	183*123*183	178	382*257*387	240,000	8.0

## Suggested thermal profiles for soldering processes

- 1.Storage environment: Temperature=5°C~40°C Humidity=55%±25%
- 2.Reflow soldering of surface-mount devices

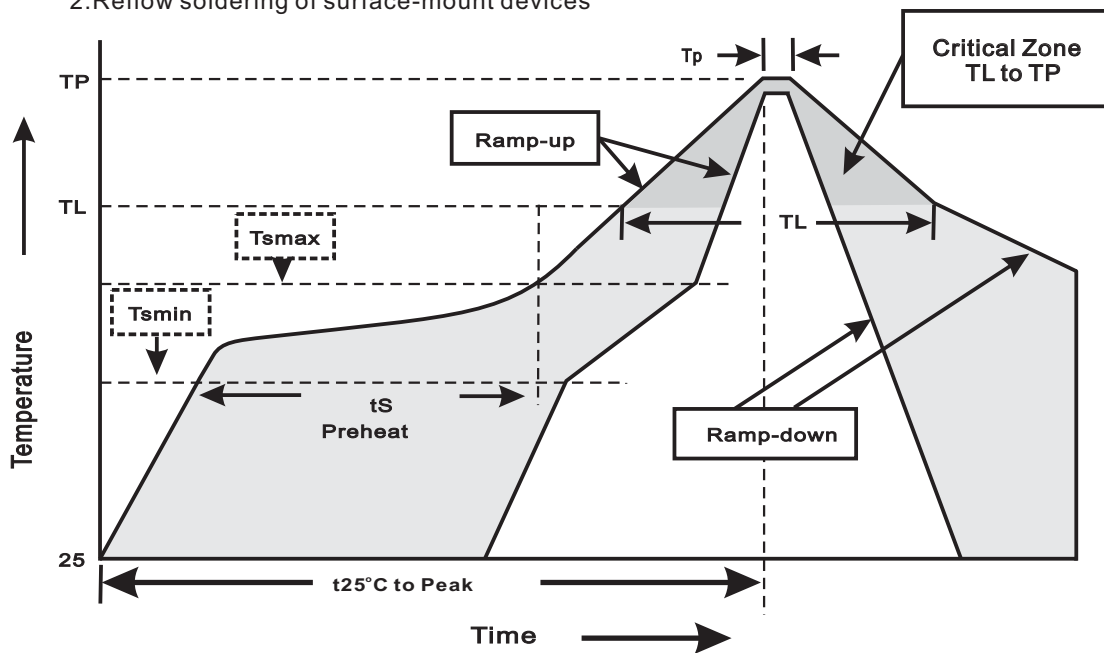

### 3.Reflow soldering

Profile Feature	Soldering Condition
Average ramp-up rate(TL to TP)	<3°C/sec
Preheat -Temperature Min(Tsmin) -Temperature Max(Tsmax) -Time(min to max)(ts)	150°C 200°C 60~120sec
Tsmax to TL -Ramp-upRate	<3°C/sec
Time maintained above: -Temperature(TL) -Time(tL)	217°C 60~260sec
Peak Temperature(TP)	255°C-0/+5°C
Time within 5°C of actual Peak Temperature(tp)	10~30sec
Ramp-down Rate	<6°C/sec
Time 25°C to Peak Temperature	<6minutes

**FM2L40-N****High reliability test capabilities**

Item Test	Conditions	Reference
1. Solder Resistance	at 260±5°C for 10±2sec.	MIL-STD-750D METHOD-2031
2. Solderability	at 245±5°C for 5 sec.	MIL-STD-202F METHOD-208
3. High Temperature Reverse Bias	$V_R=80\%$ rate at $T_J=125^\circ\text{C}$ for 168 hrs.	MIL-STD-750D METHOD-1038
4. Forward Operation Life	Rated average rectifier current at $T_A=25^\circ\text{C}$ for 500hrs.	MIL-STD-750D METHOD-1027
5. Intermittent Operation Life	$T_A = 25^\circ\text{C}$ , $I_F = I_O$ On state: power on for 5 min. off state: power off for 5 min. on and off for 500 cycles.	MIL-STD-750D METHOD-1036
6. Pressure Cooker	15P <sub>SIG</sub> at $T_A=121^\circ\text{C}$ for 4 hrs.	JESD22-A102
7. Temperature Cycling	-55°C to +125°C dwelled for 30 min. and transferred for 5min. total 10 cycles.	MIL-STD-750D METHOD-1051
8. Forward Surge	1.0ms square-wave , one surge.	MIL-STD-750D METHOD-4066-2
9. Humidity	at $T_A=85^\circ\text{C}$ , RH=85% for 1000hrs.	MIL-STD-750D METHOD-1021
10. High Temperature Storage Life	at 175°C for 1000 hrs.	MIL-STD-750D METHOD-1031