

FMOSGTQC390N10-H

List

List..... 1

Package outline..... 2

Features..... 2

Applications..... 2

Mechanical data..... 2

Maximum ratings 2

Electrical characteristics..... 3

Rating and characteristics curves..... 4~6

Pinning information..... 7

Marking..... 7

Reel packing..... 8

Suggested thermal profiles for soldering processes..... 8

FMOSGTQC390N10-H

390A 100V N-Channel Shield Gate Trench Enhancement Mode Power MOSFET

Features

- $V_{DS}=100V, I_D=390A$.
- $R_{DS(ON)} \leq 1.3 m\Omega, @V_{GS}=10V, I_D=20A$.
- Excellent $R_{DS(ON)}$ and low gate charge.
- 100% UIS and R_g tested.
- Lead-free parts meet RoHS requirements.
- Halogen-free (IEC61249-2-21).

Applications

- Load Switch.
- PWM Application.
- Power Management.

Mechanical data

- Epoxy:UL94-V0 rated flame retardant.
- Case: Molded plastic, TOLL-8L (MO-299A).
- Weight : Approximated 760mg.

Package outline

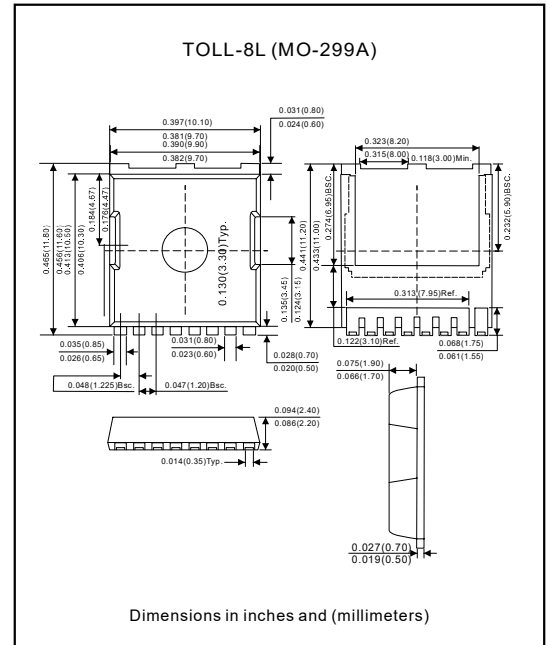

Maximum ratings (At $T_J=25^\circ C$ unless otherwise specified)

Parameter	Symbol	Ratings	Unit
Drain to source voltage	V_{DS}	100	V
Gate-source voltage	V_{GS}	± 20	V
Continuous drain current	I_D	($T_c=25^\circ C$)	390
		($T_c=100^\circ C$)	245
Pulsed drain current (Note 1)	I_{DM}	1330	A
Single pulsed, avalanche energy (Note 2)	E_{AS}	1983	mJ
Power dissipation	P_D	($T_c=25^\circ C$)	355
		($T_c=100^\circ C$)	141
Thermal resistance, junction to ambient (Note 3)	$R_{\theta JA}$	33	$^\circ C/W$
Thermal resistance, junction to case	$R_{\theta JC}$	0.35	$^\circ C/W$
Junction temperature	T_J	+150	$^\circ C$
Storage temperature range	T_{STG}	-55 to +150	$^\circ C$

FMOSGTQC390N10-H

Electrical characteristics (At $T_J=25^\circ\text{C}$ unless otherwise noted)

Parameter	Symbol	Conditions	Min	Typ	Max	Unit
Off characteristics						
Drain-source breakdown voltage	BV_{DSS}	$I_D=250\mu\text{A}$, $V_{GS}=0\text{V}$	100			V
Drain-source leakage current	I_{DSS}	$V_{DS}=80\text{V}$, $V_{GS}=0\text{V}$, $T_J=25^\circ\text{C}$			1	μA
Gate-source leakage current	I_{GSS}	$V_{GS}=\pm 20\text{V}$, $V_{DS}=0\text{V}$			± 100	nA

On characteristics

Gate threshold voltage	$V_{GS(TH)}$	$V_{DS}=V_{GS}$, $I_D=250\mu\text{A}$	2.0	2.9	3.8	V
Static drain-source on-state resistance	$R_{DS(ON)}$	$V_{GS}=10\text{V}$, $I_D=20\text{A}$		1	1.3	$\text{m}\Omega$
Gate resistance	R_g	$V_{DS}=0\text{V}$, $V_{GS}=0\text{V}$, $f=1.0\text{MHz}$		3.8		Ω

Dynamic parameters (Note 2)

Input capacitance	C_{iss}	$V_{GS}=0\text{V}$, $V_{DS}=50\text{V}$, $f=1.0\text{MHz}$		13325		pF
Out capacitance	C_{oss}			5110		
Reverse transfer capacitance	C_{rss}			121		

Switching parameters (Note 2)

Total gate charge	Q_g	$V_{GS}=0$ to 10V , $V_{DS}=50\text{V}$, $I_D=20\text{A}$		213		nC
Gate to source charge	Q_{gs}			67		
Gate to drain charge	Q_{gd}			59		
Turn-on delay time	$t_{d(on)}$	$V_{DS}=50\text{V}$, $V_{GS}=10\text{V}$, $I_D=20\text{A}$, $R_G=3.0\Omega$		41		ns
Rise time	t_r			68		
Turn-off delay time	$t_{d(off)}$			156		
Fall time	t_f			91		

Source-drain diode ratings and characteristics

Source-Drain forward voltage drop	V_{SD}	$I_S=20\text{A}$, $V_{GS}=0\text{V}$			1.2	V
Source-Drain continuous current	I_S	Integral reverse P-N junction diode in the MOSFET			392	A
Source-Drain pulse current	I_{SM}				2568	
Body diode reverse recovery time	t_{rr}	$V_{GS}=0\text{V}$, $I_F=20\text{A}$, $diF/dt=100\text{A}/\mu\text{s}$		130		ns
Body diode reverse recovery charge	Q_{rr}			372		nC

Notes :

1. Repetitive Rating: Pulse Width Limited by Maximum Junction Temperature.
2. EAS condition: Starting $T_J=25^\circ\text{C}$, $V_{DD}=50\text{V}$, $V_{GS}=10\text{V}$, $R_G=25\text{ohm}$, $L=3\text{mH}$, $I_{AS}=36.4\text{A}$, $V_{DD}=0\text{V}$ during time in avalanche.
3. $R_{\theta JA}$ is measured with the device mounted on a 1inch^2 pad of 2oz copper FR4 PCB.
4. Pulse Test: Pulse Width $\leq 300\mu\text{s}$, Duty Cycles $\leq 0.5\%$.

FMOSGTQC390N10-H

Rating and characteristics curves

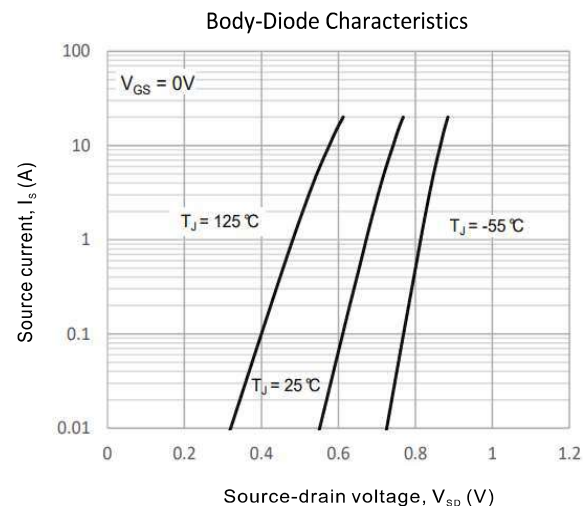
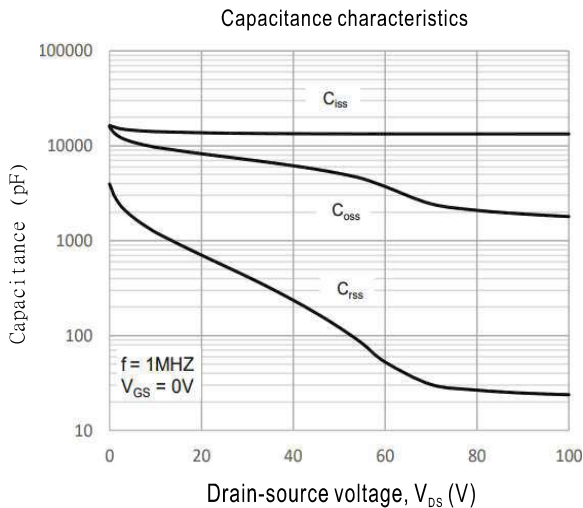
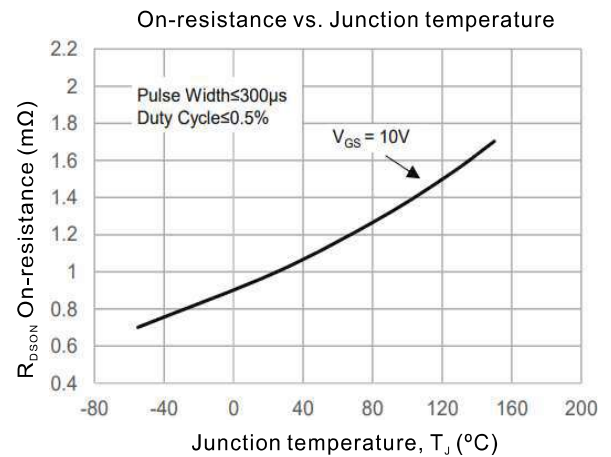
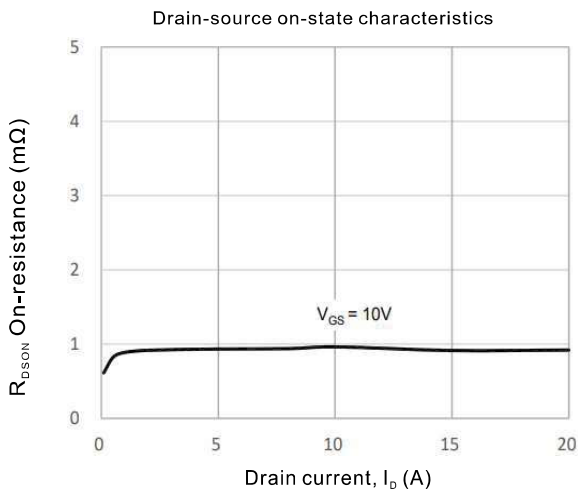
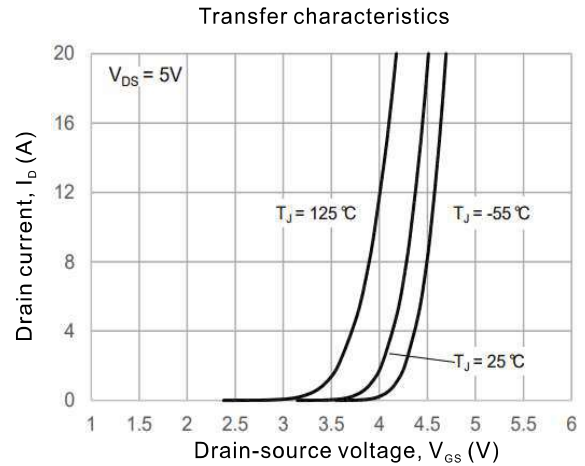
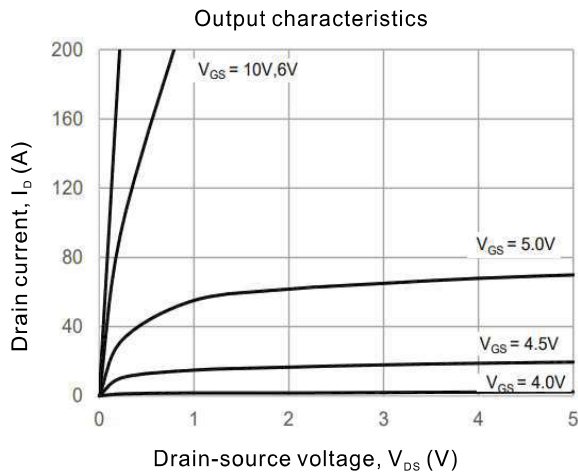

FMOSGTQC390N10-H

Rating and characteristics curves

On-resistance vs. Gate-source voltage

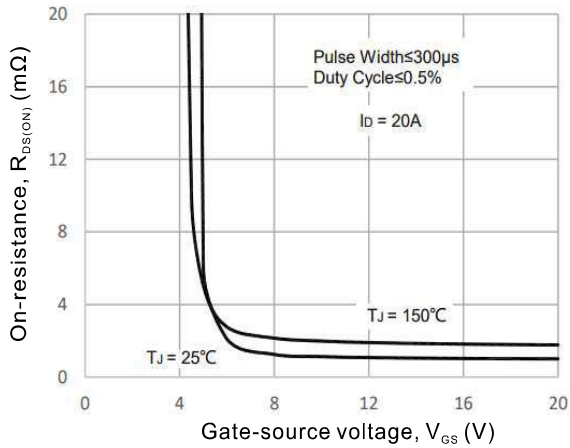

Gate charge characteristics

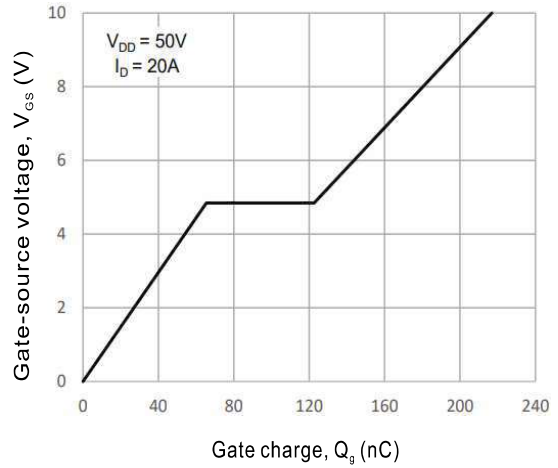

Current derating

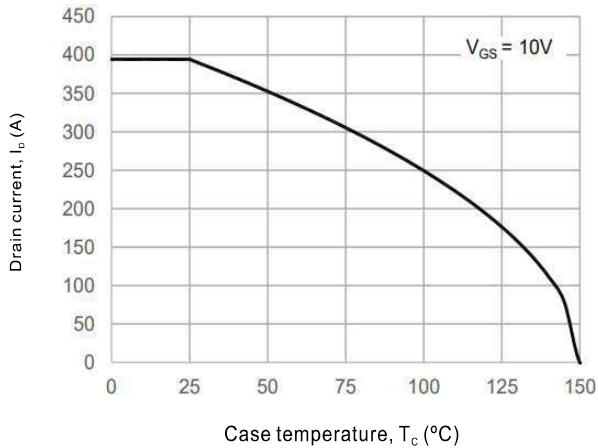

Power derating

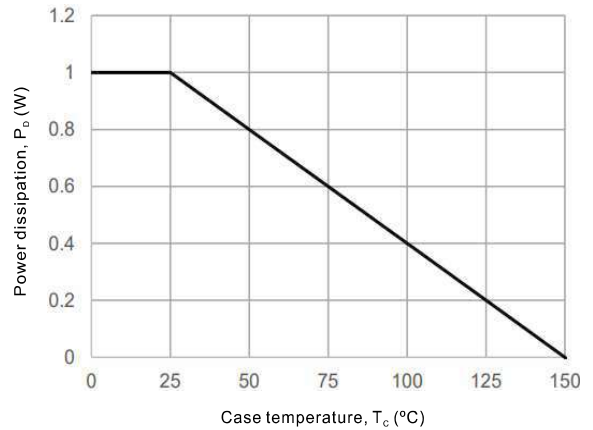

Safe operating area

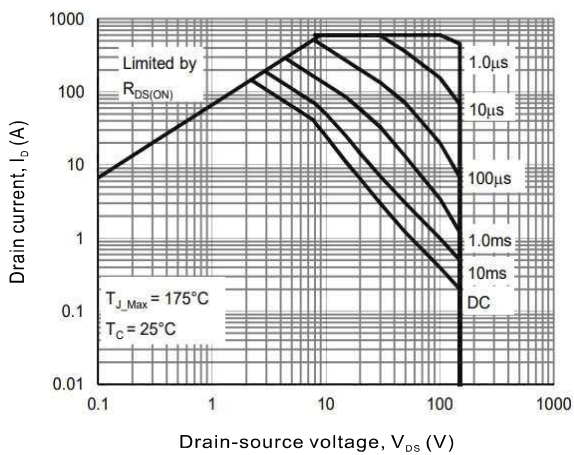

Drain-source breakdown voltage vs. Junction temperature

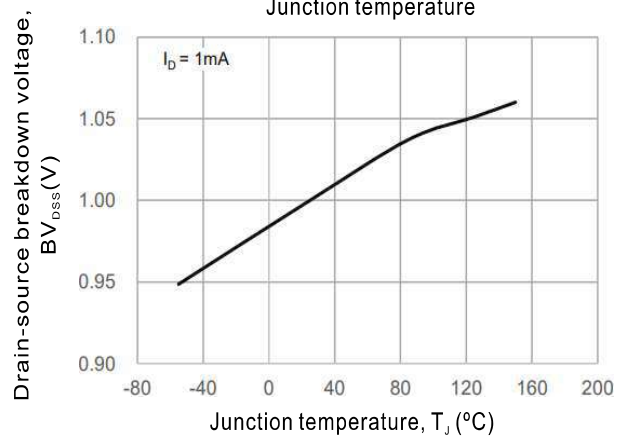

FMOSGTQC390N10-H

Rating and characteristics curves

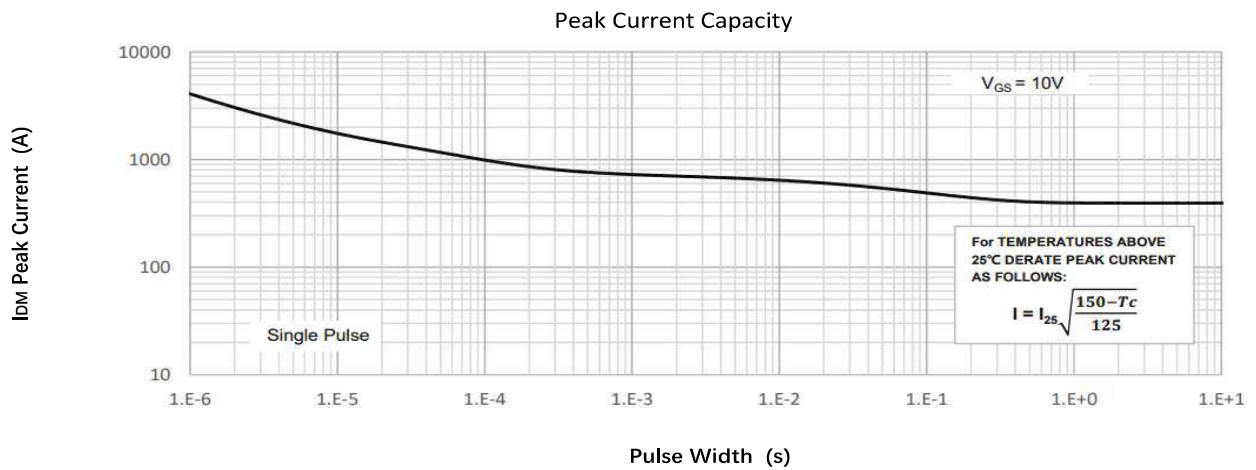
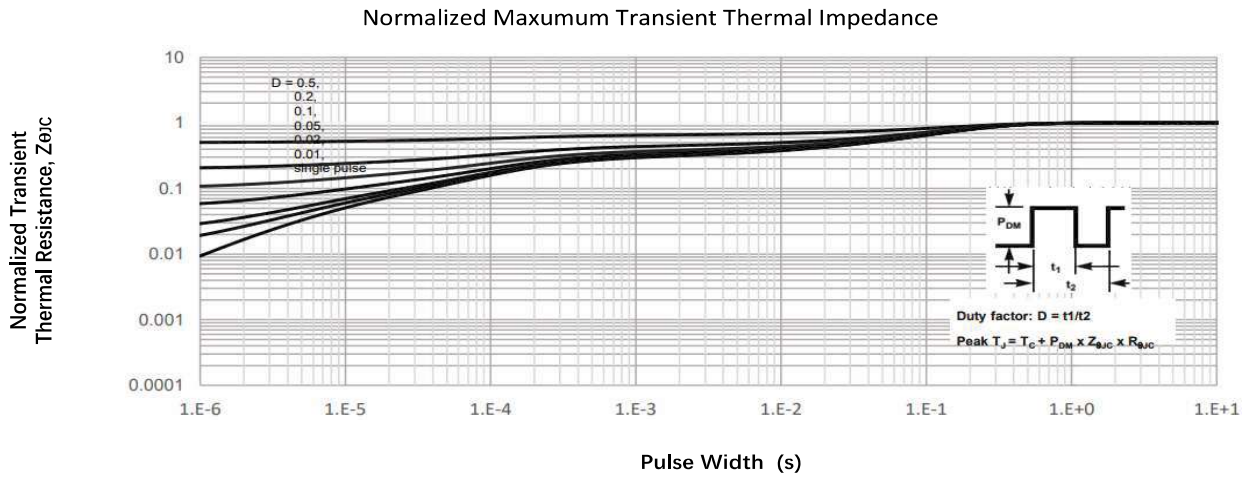

FMOSGTQC390N10-H

Pinning information

Pin	Simplified outline	Symbol
Pin 1 Gate Pin 2, 3, 4, 5, 6, 7, 8 Source Pin 9 Drain		

Marking

Type number	Marking code
FMOSGTQC390N10-H	PSW1013T YYWWX

*YYWWX: Wafer lot code
 YY: Year
 WW: Week
 X: Assy. code

Suggested solder pad layout

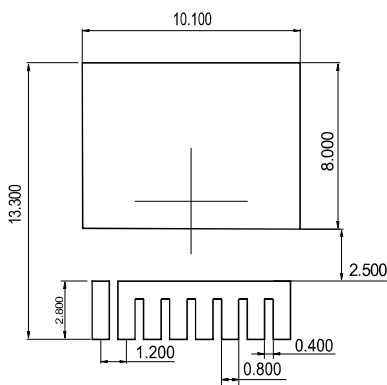

Note:
 1. Controlling dimension: in millimeters.
 2. General tolerance: ± 0.1 mm.
 3. The pad layout is for reference purposes only.

FMOSGTQC390N10-H

Reel packing

DEVICE	PACKAGE	REEL SIZE	REEL (pcs)
FMOSGTQC390N10-H	TOLL-8L	13"	2,000

Suggested thermal profiles for soldering processes

1. Storage environment : Temperature = 5°C ~ 40°C, Humidity = 55%, ±25%.
2. Reflow soldering of surface - Mount devices.

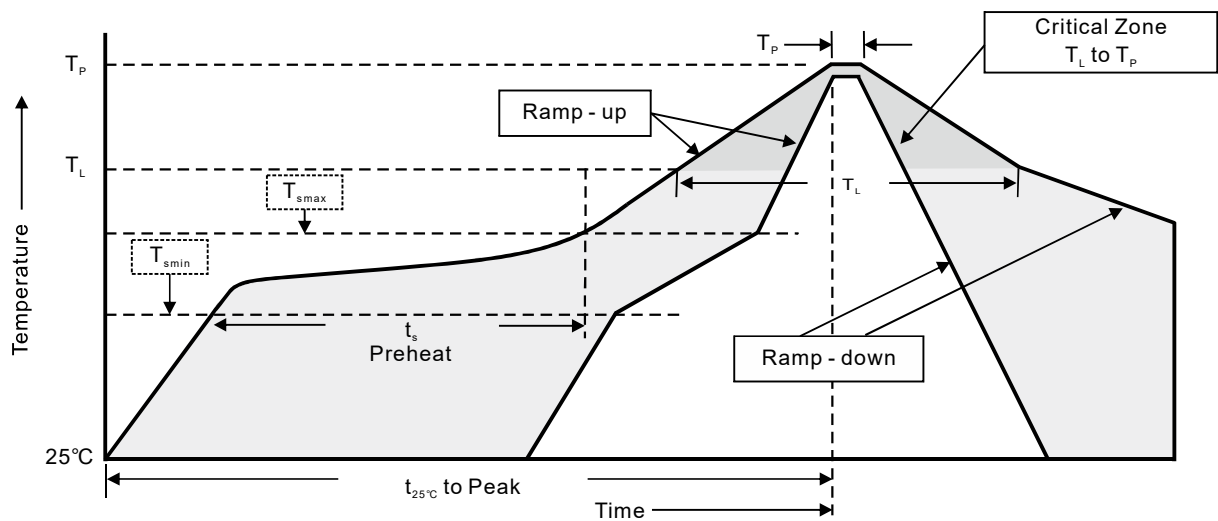

3. Reflow soldering

Profile feature	Soldering condition
Average ramp-up rate (T_L to T_p)	< 3 °C/sec
Preheat - Temperature Min (T_{smin}) - Temperature Max (T_{smax}) - Time (Min to Max) (t_s)	150°C 200°C 60 ~ 120 sec
T_{smax} to T_L - Ramp-up rate	< 3 °C / sec
Time maintained above : - Temperature (T_L) - Time (T_L)	217°C 60 ~ 260 sec
Peak temperature (T_p)	255 °C -0 / +5°C
Time with 5°C of actual peak temperature (T_p)	10 ~ 30 sec
Ramp-down rate	< 6°C / sec
Time 25°C to peak temperature	< 6 minutes