

FMOS3400A

List

List.....	1
Package outline.....	2
Features.....	2
Mechanical data.....	2
Maximum ratings	2
Electrical characteristics.....	3
Rating and characteristic curves.....	4
Pinning information.....	5
Marking.....	5
Suggested solder pad layout.....	5
Packing information.....	6
Reel packing.....	7
Suggested thermal profiles for soldering processes.....	7
High reliability test capabilities.....	8

FMOS3400A

30V N-Channel Enhancement Mode MOSFET

Features

- High dense cell design for extremely low $R_{DS(ON)}$
- Exceptional on-resistance and maximum DC current capability
- Lead -free parts meet RoHS requirements
- Suffix "-H" dinicates Halogen-free part, ex.FMOS3400A-H

Application

- Load/Power switching
- Interfacing switching

Mechanical data

- Epoxy : UL94-V0 rated flame retardant
- Case : Molded plastic, SOT-23
- Terminals : Solder plated, solderable per MIL-STD-750, Method 2026
- Mounting position : Any
- Weight : Approximated 0.008 gram

Package outline

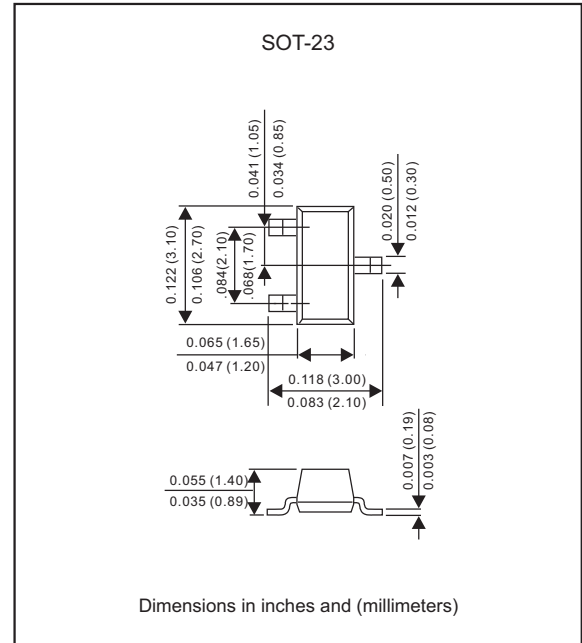

Maximum ratings (AT $T_A=25\text{ }^\circ\text{C}$ unless otherwise noted)

Parameter	Symbol	MIN.	TYP.	MAX.	Unit
Drain-source voltage	V_{DS}			30	V
Continuous drain current	I_D			5.8	A
Drain current-pulsed (Note 1)	I_{DM}			30	A
Gate - source voltage	V_{GS}			± 12	V
Power dissipation	P_D			400	mW
Thermal resistance junction to ambient (Note 2)	$R_{\theta JA}$			313	$^\circ\text{C/W}$
Operation junction temperature range	T_J	-55		+150	$^\circ\text{C}$
Storage temperature range	T_{STG}	-55		+150	$^\circ\text{C}$

Notes 1: Repetitive Rating : Pulse width limited by maximum junction temperature
 2: Surface Mounted on FR4 Board, $t < 5\text{ sec}$

FMOS3400A

Electrical characteristics (At $T_A=25\text{ }^\circ\text{C}$ unless otherwise noted)

Parameter	Conditions	Symbol	MIN.	TYP.	MAX.	Unit
Off characteristics						
Drain-source breakdown voltage	$V_{GS} = 0V, I_D = 250\mu A$	$V_{(BR)DSS}$	30			V
Zero gate voltage drain current	$V_{DS} = 24V, V_{GS} = 0V$	I_{DSS}			1.0	μA
Gate-source leakage current	$V_{GS} = \pm 12V, V_{DS} = 0V$	I_{GSS}			± 100	nA
On characteristics (Note 1)						
Gate threshold voltage	$V_{DS} = V_{GS}, I_D = 250\mu A$	$V_{GS(th)}$	0.6		1.5	V
Drain-source on-resistance	$V_{GS} = 10V, I_D = 5.8A$ $V_{GS} = 4.5V, I_D = 5.0A$	$R_{DS(ON)}$			35 40	$m\Omega$
Forward transconductance	$V_{DS} = 5.0V, I_D = 5A$	g_{FS}	8.0			S

Dynamic characteristics (Note 2)

Input capacitance	$V_{DS} = 15V, V_{GS} = 0V, f = 1MHz$	C_{iss}			1155	pF
Output capacitance		C_{oss}		108		
Reverse transfer capacitance		C_{rss}		84		
Gate resistance	$V_{DS} = 0V, V_{GS} = 0V, f = 1MHz$	R_G			3.6	Ω

Switching characteristics (Note 2)

Turn-on delay time	$V_{GS} = 10V, V_{DS} = 15V,$ $R_L = 2.7\Omega, R_{GEN} = 3.0\Omega$	$t_d(on)$			5.0	ns
Turn-on rise time		t_r			7.0	
Turn-off delay time		$t_d(off)$			40	
Turn-off fall time		t_f			6.0	

Drain source diode characteristics and maximum ratings

Diode forward voltage (Note 1)	$I_S = 1.0A, V_{GS} = 0V$	V_{SD}			1.0	V
--------------------------------	---------------------------	----------	--	--	-----	---

Notes 1: Pulse test: pulse width $\leq 300\mu s$, duty cycle $\leq 2\%$

2: Guaranteed by design, not subject to production testing

Rating and characteristic curves (FMOS3400A)

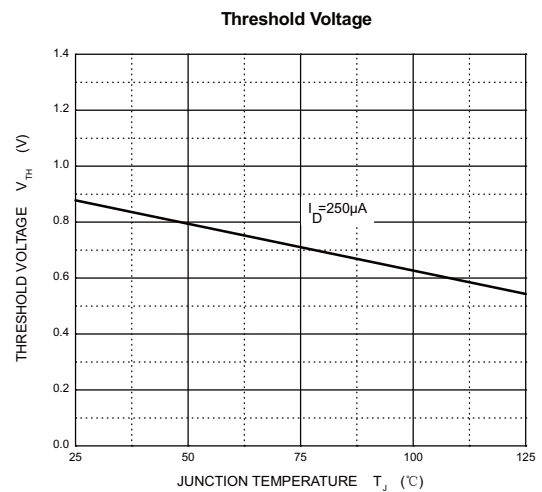
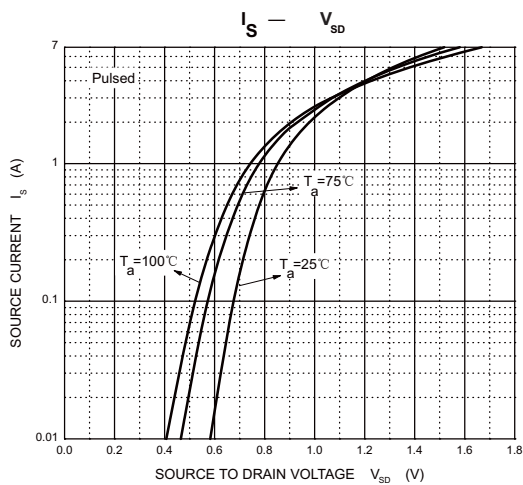
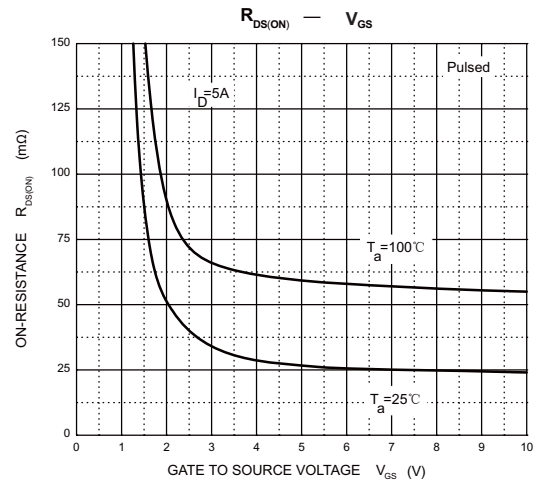
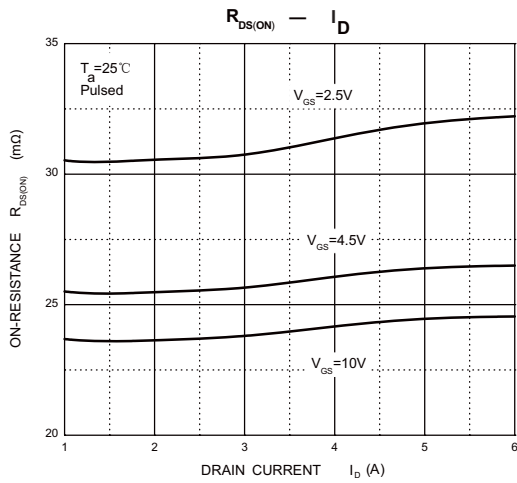
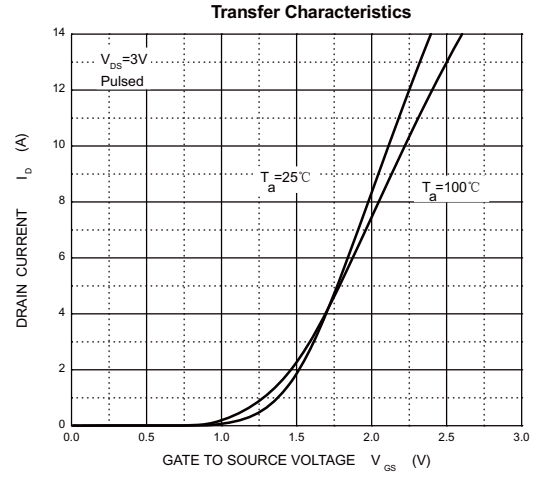
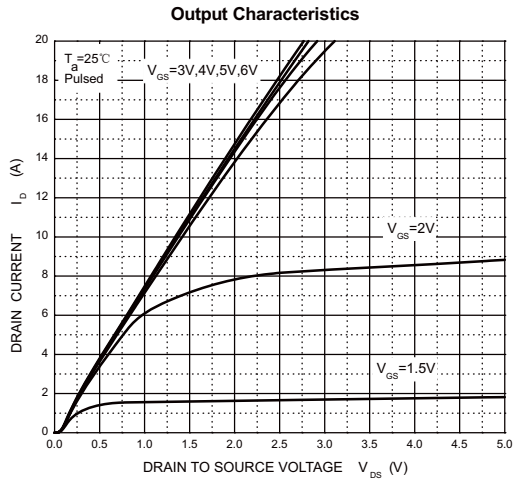

FMOS3400A

Pinning information

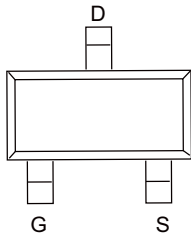
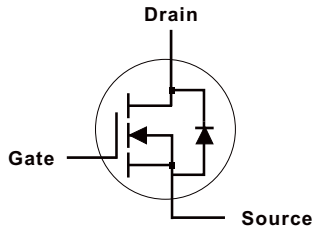
Pin	Simplified outline	Symbol
Pin D Drain Pin G Gate Pin S Source		

Marking

Type number	Marking code
FMOS3400A	R0A, 3400, L3400, R0

Suggested solder pad layout

SOT-23

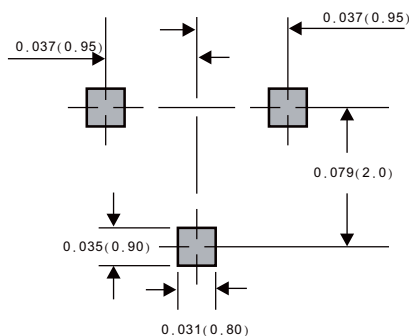

Dimensions in inches and(millimeters)

FMOS3400A

Reel packing

PACKAGE	REEL SIZE	REEL (pcs)	COMPONENT SPACING (m/m)	BOX (pcs)	INNER BOX (m/m)	REEL DIA, (m/m)	CARTON SIZE (m/m)	CARTON (pcs)	APPROX. GROSS WEIGHT (kg)
SOT-23	7"	3,000	4.0	30,000	183*123*183	178	382*257*387	240,000	11.6

Suggested thermal profiles for soldering processes

- 1.Storage environment: Temperature=5°C~40°C Humidity=55%±25%
- 2.Reflow soldering of surface-mount devices

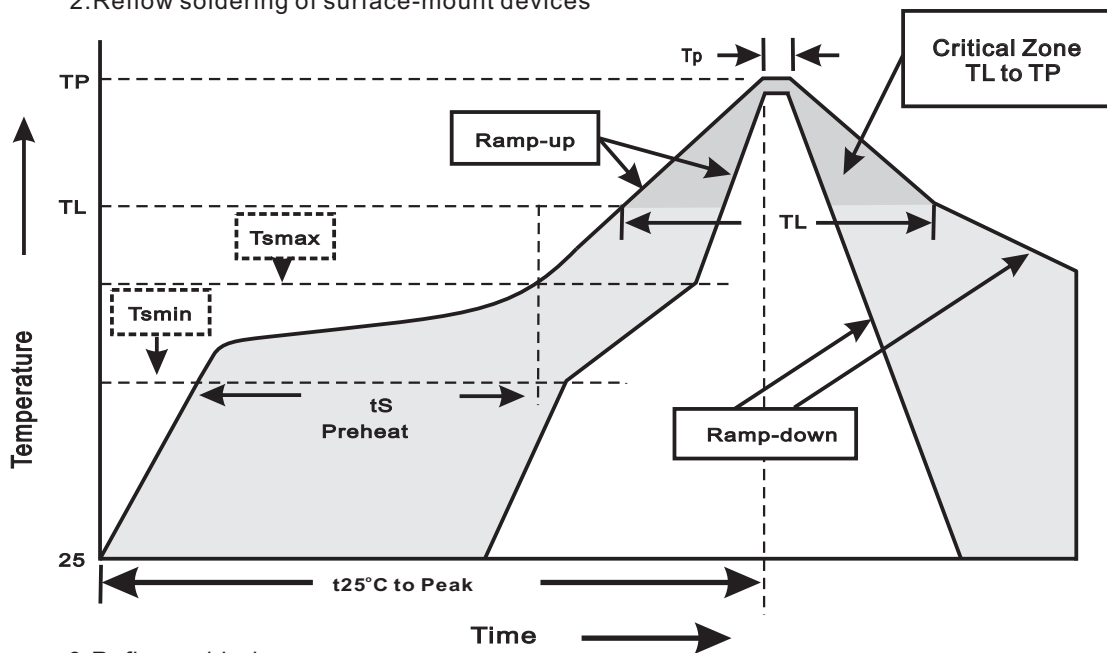

- 3.Reflow soldering

Profile Feature	Soldering Condition
Average ramp-up rate(TL to TP)	<3°C/sec
Preheat -Temperature Min(Tsmin) -Temperature Max(Tsmax) -Time(min to max)(ts)	150°C 200°C 60~120sec
Tsmax to TL -Ramp-upRate	<3°C/sec
Time maintained above: -Temperature(TL) -Time(tL)	217°C 60~260sec
Peak Temperature(Tp)	255°C-0/+5°C
Time within 5°C of actual Peak Temperature(tp)	10~30sec
Ramp-down Rate	<6°C/sec
Time 25°C to Peak Temperature	<6minutes

FMOS3400A

High reliability test capabilities

Item Test	Conditions	Reference
1. High Temperature Gate Bias	Ta=150°C Vgs=0, 8 x BVGSS for 1000hours	JESD22-A108-C
2. High Temperature Reverse Bias	Ta=150°C Vds=0, 8 x BVDSS for 1000hours	JESD22-A108-C
3. Solder ability Test	Temp=245°C for 5sec	JESD22-B102-D
4. Pressure Cooker Test	Ta=121°C/ 100%RH Pressure=2Atm for 168hours	JESD22-A102-C
5. Temperature Cycle Test	-65°C/ 10min~ 150°C/ 10min Transfer<5min. total 1000 cycles.	JESD22-A104-B
6. Temperature Humidity Test	Ta=85°C Humidity=85%RH for 1000hours	JESD22-A101-B
7. High Temperature Storage Test	Ta=150°C for 1000hours	JESD22-B103-B