

# FM301 THRU FM307

## List

List.....	1
Package outline.....	2
Features.....	2
Mechanical data.....	2
Maximum ratings and Electrical characteristics .....	2
Rating and characteristic curves.....	3
Pinning information.....	4
Marking.....	4
Suggested solder pad layout.....	4
Packing information.....	5
Reel packing.....	6
Suggested thermal profiles for soldering processes.....	6
High reliability test capabilities.....	7

# FM301 THRU FM307

## 3.0A Surface Mount General Purpose Rectifiers 50V-1000V

### Features

- Batch process design, excellent power dissipation offers better reverse leakage current and thermal resistance
- Low profile surface mounted application in order to optimize board space
- High current capability
- High surge capability
- Glass passivated chip junction
- Lead free parts meet RoHS requirements
- Suffix "-H" indicates Halogen-free parts, ex. FM301-H

### Mechanical data

- Epoxy:UL94-V0 rated flame retardant
- Case : Molded plastic, SMC
- Terminals : Solder plated, solderable per MIL-STD-750, Method 2026
- Polarity : Indicated by cathode band
- Mounting Position : Any
- Weight : Approximated 0.19 gram

### Package outline

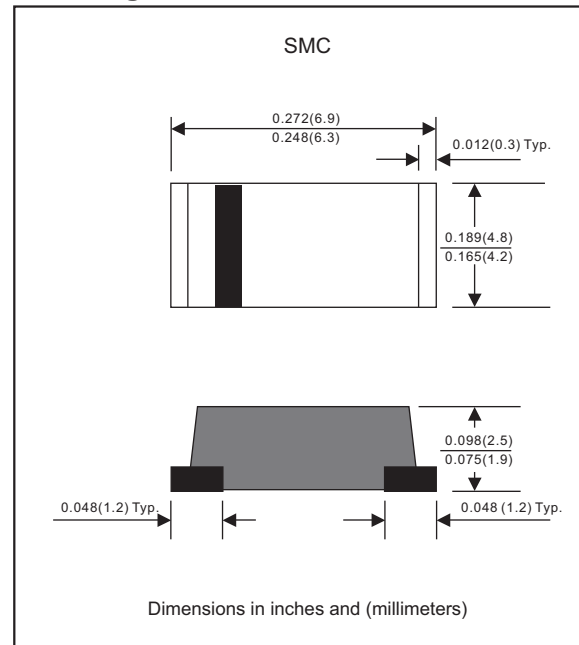

### Maximum ratings (AT $T_A=25^{\circ}\text{C}$ unless otherwise noted)

PARAMETER	SYMBOLS	FM301	FM302	FM303	FM304	FM305	FM306	FM307	UNIT
Maximum repetitive peak reverse voltage	$V_{RRM}$	50	100	200	400	600	800	1000	V
Maximum RMS voltage	$V_{RMS}$	35	70	140	280	420	560	700	V
Maximum continuous reverse voltage	$V_R$	50	100	200	400	600	800	1000	V
Maximum average forward rectified current	$I_o$	3.0							A
Non-repetitive peak forward surge current 8.3ms single half sine-wave (JEDEC methode)	$I_{FSM}$	100							A
Typical junction capacitance, Note1	$C_J$	40							pF
Operating junction temperature range	$T_J$	-55 to +150							$^{\circ}\text{C}$
Storage temperature range	$T_{STG}$	-65 to +175							$^{\circ}\text{C}$

### Electrical characteristics (AT $T_A=25^{\circ}\text{C}$ unless otherwise noted)

PARAMETER	SYMBOLS	FM301	FM302	FM303	FM304	FM305	FM306	FM307	UNIT
Maximum instantaneous forward voltage at $I_F=3.0A$	$V_F$	1.1							V
Maximum reverse leakage current at rated $V_R$	$I_R$	5.0 250							$\mu\text{A}$ $\mu\text{A}$

### Thermal characteristics

PARAMETER	SYMBOLS	FM301	FM302	FM303	FM304	FM305	FM306	FM307	UNIT
Typical thermal resistance junction to ambient, Note2	$R_{\theta JA}$	30							$^{\circ}\text{C}/\text{W}$
Typical thermal resistance junction to case, Note2	$R_{\theta JC}$	15							$^{\circ}\text{C}/\text{W}$

Notes 1: Measured at 1MHz and applied reverse voltage of 4.0V D.C  
 2: Mounted on FR-4 PCB copper, minimum recommended pad layout

## Rating and characteristic curves (FM301 THRU FM307)

FIG.1-TYPICAL FORWARD CHARACTERISTICS

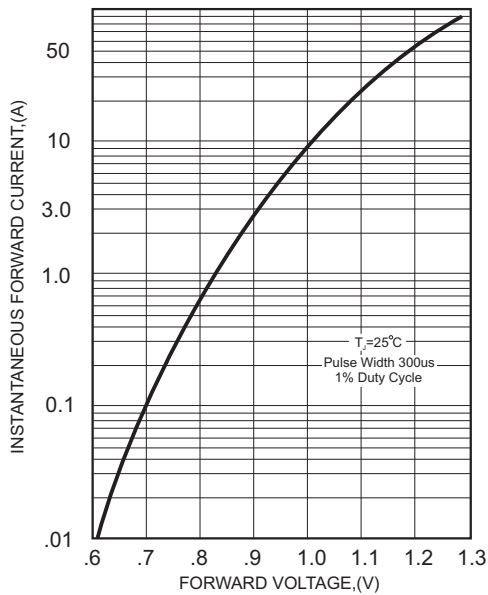

FIG.2-TYPICAL FORWARD CURRENT DERATING CURVE

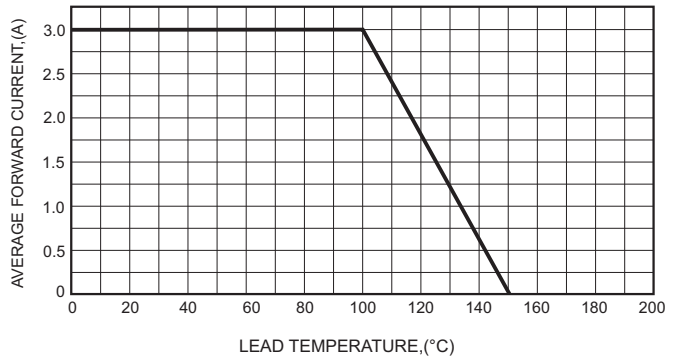

FIG.4-MAXIMUM NON-REPETITIVE FORWARD SURGE CURRENT

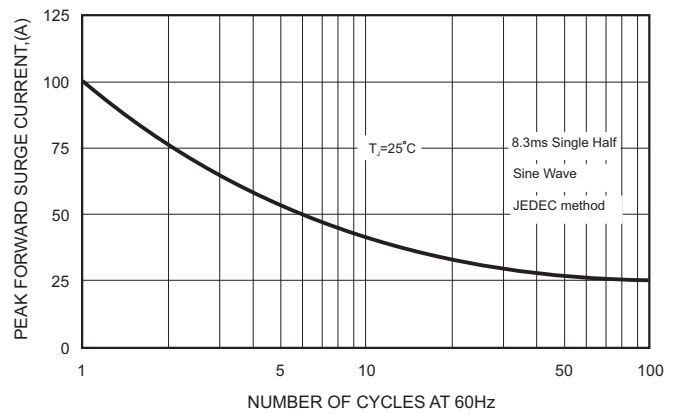

FIG.3 - TYPICAL REVERSE CHARACTERISTICS

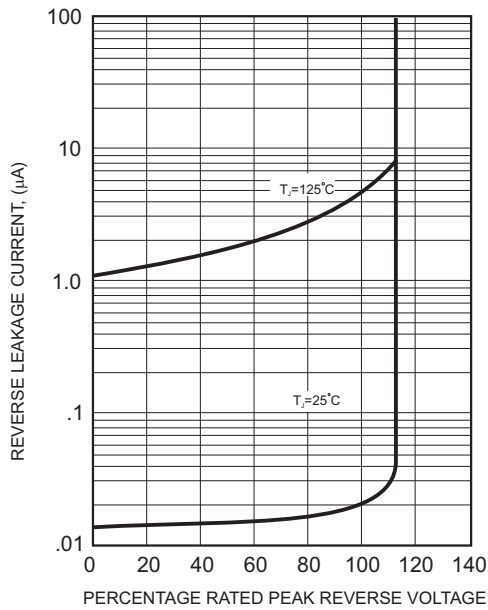
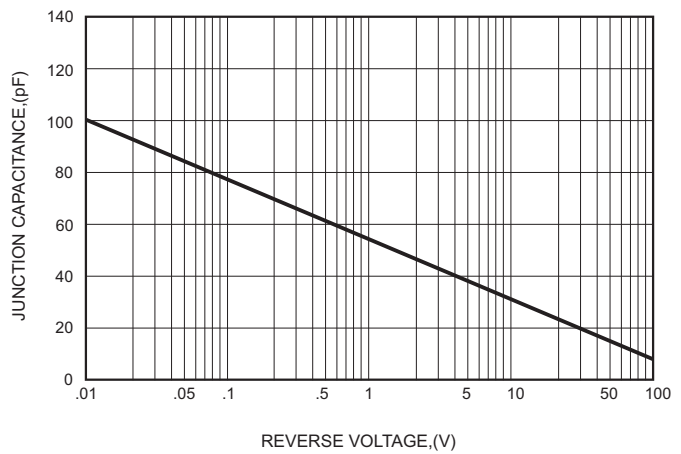



FIG.5-TYPICAL JUNCTION CAPACITANCE



# FM301 THRU FM307

## Pinning information

Pin	Simplified outline	Symbol
Pin1 cathode Pin2 anode		

## Marking

Type number	Marking code
FM301	A31
FM302	A32
FM303	A33
FM304	A34
FM305	A35
FM306	A36
FM307	A37

## Suggested solder pad layout

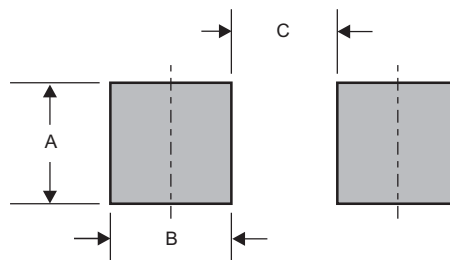

Dimensions in inches and (millimeters)

PACKAGE	A	B	C
SMC	0.189 (4.80)	0.063 (1.60)	0.158 (4.00)

# FM301 THRU FM307

## Packing information

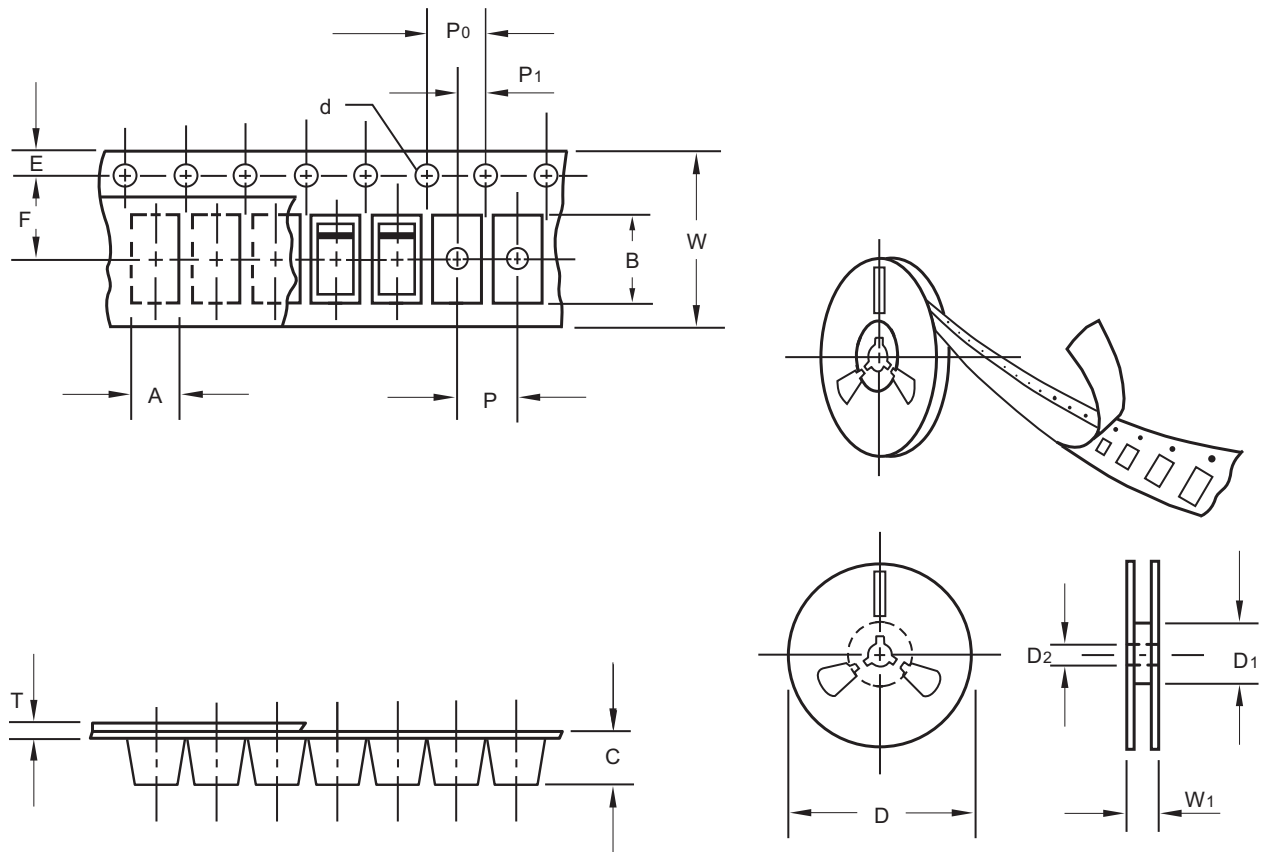

unit:mm

Item	Symbol	Tolerance	SMC
Carrier width	A	0.1	5.10
Carrier length	B	0.1	7.20
Carrier depth	C	0.1	2.50
Sprocket hole	d	0.1	1.50
13" Reel outside diameter	D	2.0	330.00
13" Reel inner diameter	D1	min	50.00
7" Reel outside diameter	D	2.0	178.00
7" Reel inner diameter	D1	min	62.00
Feed hole diameter	D2	0.5	13.00
Sprocket hole position	E	0.1	1.75
Punch hole position	F	0.1	5.50
Punch hole pitch	P	0.1	8.00
Sprocket hole pitch	P0	0.1	4.00
Embossment center	P1	0.1	2.00
Overall tape thickness	T	0.1	0.23
Tape width	W	0.3	12.00
Reel width	W1	1.0	18.00

Note: Devices are packed in accordance with EIA standard RS-481-A and specifications listed above.

# FM301 THRU FM307

## Reel packing

PACKAGE	REEL SIZE	REEL (pcs)	COMPONENT SPACING (m/m)	BOX (pcs)	INNER BOX (m/m)	REEL DIA, (m/m)	CARTON SIZE (m/m)	CARTON (pcs)	APPROX. GROSS WEIGHT (kg)
SMC	13"	3,000	8.0	6,000	335*335*38	330	350*330*360	48,000	17.0

## Suggested thermal profiles for soldering processes

- 1.Storage environment: Temperature=5°C~40°C Humidity=55%±25%
- 2.Reflow soldering of surface-mount devices

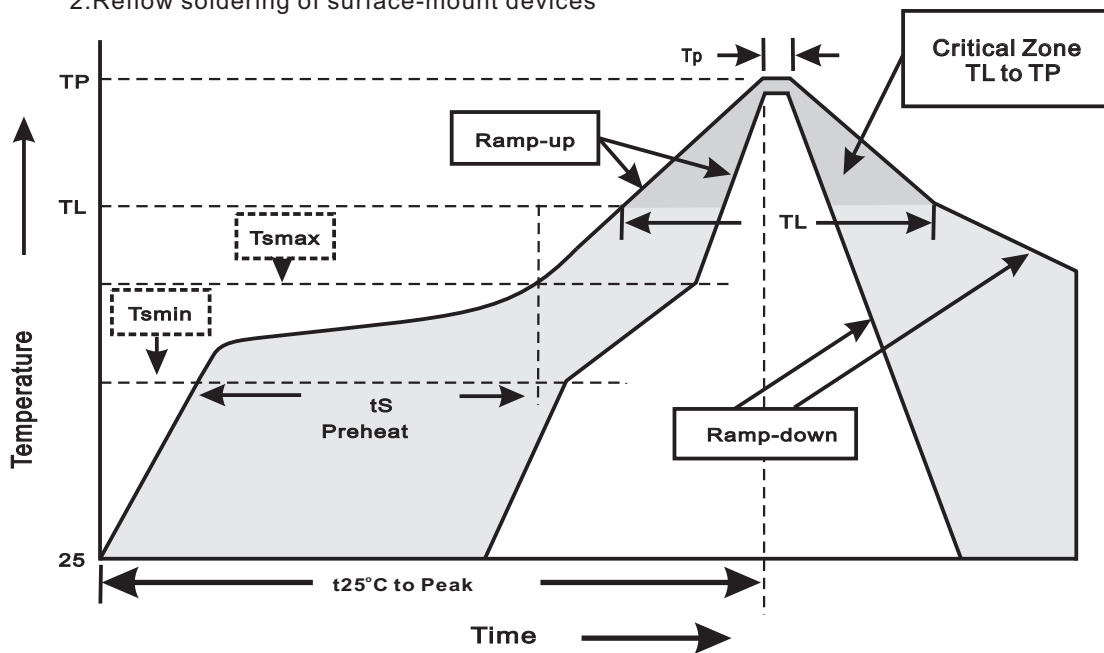

### 3.Reflow soldering

Profile Feature	Soldering Condition
Average ramp-up rate(TL to TP)	<3°C/sec
Preheat -Temperature Min(Tsmin) -Temperature Max(Tsmax) -Time(min to max)(ts)	150°C 200°C 60~120sec
Tsmax to TL -Ramp-upRate	<3°C/sec
Time maintained above: -Temperature(TL) -Time(tL)	217°C 60~260sec
Peak Temperature(TP)	255°C-0/+5°C
Time within 5°C of actual Peak Temperature(tp)	10~30sec
Ramp-down Rate	<6°C/sec
Time 25°C to Peak Temperature	<6minutes

**FM301 THRU FM307****High reliability test capabilities**

Item Test	Conditions	Reference
1. Solder Resistance	at 260±5°C for 10±2sec.	MIL-STD-750D METHOD-2031
2. Solderability	at 245±5°C for 5 sec.	MIL-STD-202F METHOD-208
3. High Temperature Reverse Bias	$V_R=80\%$ rate at $T_J=150^\circ\text{C}$ for 168 hrs.	MIL-STD-750D METHOD-1038
4. Forward Operation Life	Rated average rectifier current at $T_A=25^\circ\text{C}$ for 500hrs.	MIL-STD-750D METHOD-1027
5. Intermittent Operation Life	$T_A = 25^\circ\text{C}$ , $I_F = I_O$ On state: power on for 5 min. off state: power off for 5 min. on and off for 500 cycles.	MIL-STD-750D METHOD-1036
6. Pressure Cooker	15P <sub>SIG</sub> at $T_A=121^\circ\text{C}$ for 4 hrs.	JESD22-A102
7. Temperature Cycling	-55°C to +125°C dwelled for 30 min. and transferred for 5min. total 10 cycles.	MIL-STD-750D METHOD-1051
8. Forward Surge	8.3ms single half sine-wave , one surge.	MIL-STD-750D METHOD-4066-2
9. Humidity	at $T_A=85^\circ\text{C}$ , RH=85% for 1000hrs.	MIL-STD-750D METHOD-1021
10. High Temperature Storage Life	at 175°C for 1000 hrs.	MIL-STD-750D METHOD-1031